

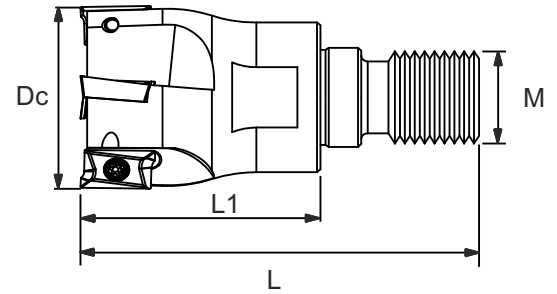

**BENTO**  
*Performance*

## Fräsen (ZETA-Mill)





**Bestellnummer (Träger)**

Bestellnummer /Order number	Abmessungen/Dimensions (mm)					Aufnahme /Holder	IKZ
	Dc	M	L	L1	z		
M90020097SM061101	9,7	M6	20	14,5	1	Schraubkupplung	●
M9002010SM061101	10	M6	20	14,5	1	Schraubkupplung	●
M90020117SM061101	11,7	M6	20	14,5	1	Schraubkupplung	●
M9002012SM061101	12	M6	20	14,5	1	Schraubkupplung	●
M90020157SM081102	15,7	M8	25	17,5	2	Schraubkupplung	●
M9002016SM081102	16	M8	25	17,5	2	Schraubkupplung	●
M90020197SM101103	19,7	M10	30	20	3	Schraubkupplung	●
M9002020SM101103	20	M10	30	20	3	Schraubkupplung	●
M90020247SM121104	24,7	M12	35	22	4	Schraubkupplung	●
M9002025SM121104	25	M12	35	22	4	Schraubkupplung	●
M90020317SM161105	31,7	M16	43	24	5	Schraubkupplung	●
M9002032SM161105	32	M16	43	24	5	Schraubkupplung	●
M9002040SM161106	40	M16	43	24	5	Schraubkupplung	●

**Ersatzteile & Zubehör / Main spare parts**

Wendeschnidplatte /Insert	Spanschraube /Span screw	Torx
M901135..	T589011	T58T07

Wendeschnidplatten und Schnittdaten siehe Seite 14/15 / For cutting inserts and cutting data, see page 14/15

P	Stahl	M	Rostfrei	K	Guss	N	Nichteisen	S	Superlegierung	H	Hochfeste Stähle
P	Steel	M	Stainless steel	K	Cast iron	N	Non-ferrous metals	S	Heat resistant and super alloy	H	Hardened materials

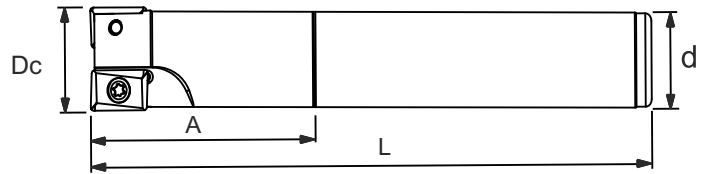

Bestellnummer (Träger)

Bestellnummer /Order number	Abmessungen/Dimensions (mm)					Aufnahme /Holder	IKZ
	Dc	d	L	A	z		
M9002010WE101001101	10	10	100	25	1	Weldon	●
M9002010WE101001102	10	10	100	25	2	Weldon	●
M9002012WE121301101	12	12	130	25	1	Weldon	●
M9002012WE121301102	12	12	130	25	2	Weldon	●
M9002016WE161201102	16	16	120	40	2	Weldon	●
M9002016WE161201103	16	16	120	40	3	Weldon	●
M9002016WE161601102	16	16	160	50	2	Weldon	●
M9002016WE161801102	16	16	180	60	2	Weldon	●
M9002016WE162001102	16	16	200	60	2	Weldon	●
M9002020WE201201102	20	20	120	50	2	Weldon	●
M9002020WE201201103	20	20	120	50	3	Weldon	●
M9002020WE201601102	20	20	160	60	2	Weldon	●
M9002020WE202001102	20	20	200	70	2	Weldon	●
M9002025WE251601103	25	25	160	70	3	Weldon	●
M9002032WE321601103	32	32	160	50	3	Weldon	●

Ersatzteile & Zubehör / Main spare parts

Wendeschnidplatte /Insert	Spanschraube /Span screw	Torx
M90-1135..	T589011	T58T07

Wendeschnidplatten und Schnittdaten siehe Seite 14/15 / For cutting inserts and cutting data, see page 14/15

P	Stahl	M	Rostfrei	K	Guss	N	Nichteisen	S	Superlegierung	H	Hochfeste Stähle
P	Steel	M	Stainless steel	K	Cast iron	N	Non-ferrous metals	S	Heat resistant and super alloy	H	Hardened materials

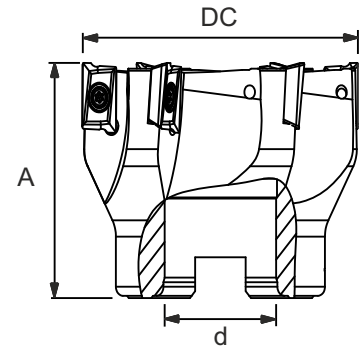



**Bestellnummer (Träger)**

Bestellnummer /Order number	Abmessungen/Dimensions (mm)				Aufnahme /Holder	IKZ
	Dc	d	A	z		
M9002040AD161104	40	16	50	4	Aufsteckdorn	●
M9002050AD221104	50	22	50	4	Aufsteckdorn	●
M9002050AD221105	50	22	50	5	Aufsteckdorn	●
M9002050AD221106	50	22	50	6	Aufsteckdorn	●
M9002054AD221104	54	22	50	4	Aufsteckdorn	●
M9002054AD221105	54	22	50	5	Aufsteckdorn	●
M9002063AD221105	63	22	50	5	Aufsteckdorn	●
M9002063AD221106	63	22	50	6	Aufsteckdorn	●
M9002066AD221107	66	11	50	7	Aufsteckdorn	●
M9002080AD271106	80	27	50	6	Aufsteckdorn	●
M9002080AD271107	80	27	50	7	Aufsteckdorn	●
M9002084AD271106	84	27	50	6	Aufsteckdorn	●
M9002084AD271107	84	27	50	7	Aufsteckdorn	●
M9002100AD321106	100	32	50	6	Aufsteckdorn	●
M9002100AD321108	100	32	50	8	Aufsteckdorn	●

**Ersatzteile & Zubehör / Main spare parts**

Wendeschneidplatte /Inseret	Spanschraube /Span screw	Torx
M90-1135..	T589011	T58T15

<b>P</b> Stahl	<b>M</b> Rostfrei	<b>K</b> Guss	<b>N</b> Nichteisen	<b>S</b> Superlegierung	<b>H</b> Hochfeste Stähle
<b>P</b> Steel	<b>M</b> Stainless steel	<b>K</b> Cast iron	<b>N</b> Non-ferrous metals	<b>S</b> Heat resistant and super alloy	<b>H</b> Hardened materials

		Beschichtung / Coating	CVD						U	U	PVD								
		ISO	P			M	K			N	N	P				M	S	K	
		Sorte / Grade	P1010	P1020	P1030	M2040	K3010	K3020	K3030	N4010	N4110	P1110	P1120	P1130	P1140	M2130	M2130	K3120	
M=Mittlere Bearbeitung		APKT1003PDSR											●						
		M90113508M2										●							
		M90113508M2											●						
		M90113508M2												●					
		M90113508M2														●	●		
		M90113508M2							●										
		M90113508M3													●				
		M90113516M6											●						
MH=Mittlere Bearbeitung / Schruppen																			
H=Schruppen		M90113508H2										●							
		M90113508H2											●						
		M90113508H2												●					
		M90113508H2					●												
		M90113508H2														●	●		
AL2=Schlichten/Mittlere Bearbeitung		M90113508AL3								●									
		M90113508AL3									●								
		M90113508AL2									●								

P	Stahl	M	Rostfrei	K	Guss	N	Nichteisen	S	Superlegierung	H	Hochfeste Stähle
P	Steel	M	Stainless steel	K	Cast iron	N	Non-ferrous metals	S	Heat resistant and super alloy	H	Hardened materials

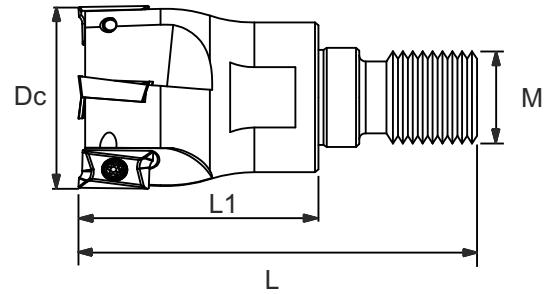

**Bestellnummer (Träger)**

Bestellnummer /Order number	Abmessungen/Dimensions (mm)					Aufnahme /Holder	IKZ
	Dc	M	L	L1	z		
M90020097SM061601	9,7	M6	20	14,5	1	Schraubkupplung	●
M9002010SM061601	10	M6	20	14,5	1	Schraubkupplung	●
M90020117SM061601	11,7	M6	20	14,5	1	Schraubkupplung	●
M9002012SM061601	12	M6	20	14,5	1	Schraubkupplung	●
M90020157SM081602	15,7	M8	25	17,5	2	Schraubkupplung	●
M9002016SM081602	16	M8	25	17,5	2	Schraubkupplung	●
M90020197SM101602	19,7	M10	30	20	3	Schraubkupplung	●
M9002020SM101602	20	M10	30	20	3	Schraubkupplung	●
M90020247SM121603	24,7	M12	35	22	4	Schraubkupplung	●
M9002025SM121603	25	M12	35	22	4	Schraubkupplung	●
M90020317SM161603	31,7	M16	43	24	5	Schraubkupplung	●
M9002032SM161603	32	M16	43	24	5	Schraubkupplung	●
M9002040SM161604	40	M16	43	24	5	Schraubkupplung	●

Ersatzteile & Zubehör / Main spare parts

Wendeschneidplatte /Inseret	Spanschraube /Span screw	Torx
M901604..	T589016	T58T15

P	Stahl	M	Rostfrei	K	Guss	N	Nichteisen	S	Superlegierung	H	Hochfeste Stähle
P	Steel	M	Stainless steel	K	Cast iron	N	Non-ferrous metals	S	Heat resistant and super alloy	H	Hardened materials

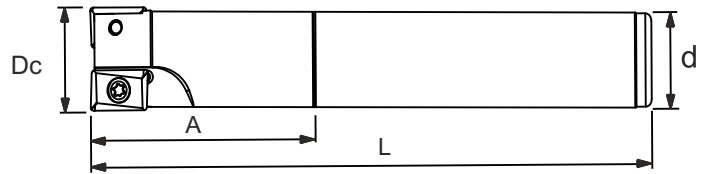

**Bestellnummer (Träger)**

Bestellnummer /Order number	Abmessungen/Dimensions (mm)					Aufnahme /Holder	IKZ
	Dc	d	L	A	z		
M9002025WE251601602	25	25	160	70	2	Weldon	●
M9002025WE251601603	25	25	160	70	3	Weldon	●
M9002025WE252001602	25	25	200	70	2	Weldon	●
M9002025WE252501602	25	25	250	80	2	Weldon	●
M9002025WE253001602	25	25	300	80	2	Weldon	●
M9002032WE321601602	32	32	160	48	2	Weldon	●
M9002032WE321601603	32	32	160	48	3	Weldon	●
M9002032WE322001602	32	32	200	48	2	Weldon	●
M9002032WE322501602	32	32	250	48	2	Weldon	●
M9002035WE321601602	35	32	160	48	2	Weldon	●
M9002035WE321601603	35	32	160	48	3	Weldon	●
M9002035WE322001602	35	32	200	48	2	Weldon	●
M9002035WE322001603	35	32	200	48	3	Weldon	●
M9002035WE322501602	35	32	250	60	2	Weldon	●
M9002035WE322501603	35	32	250	60	3	Weldon	●
M9002035WE323001602	35	32	300	60	2	Weldon	●
M9002035WE323001603	35	32	300	60	3	Weldon	●
M9002035WE324001603	35	32	400	60	3	Weldon	●
M9002035WE325001603	35	32	500	60	3	Weldon	●
M9002040WE322001603	40	32	200	60	3	Weldon	●
M9002040WE322001604	40	32	200	60	4	Weldon	●
M9002040WE322501603	40	32	250	60	3	Weldon	●
M9002040WE323001603	40	32	300	60	3	Weldon	●

**Ersatzteile & Zubehör / Main spare parts**

Wendeschneidplatte /Inseret	Spanschraube /Span screw	Torx
M90-1604..	T589016	T58T15

P	Stahl	M	Rostfrei	K	Guss	N	Nichteisen	S	Superlegierung	H	Hochfeste Stähle
P	Steel	M	Stainless steel	K	Cast iron	N	Non-ferrous metals	S	Heat resistant and super alloy	H	Hardened materials

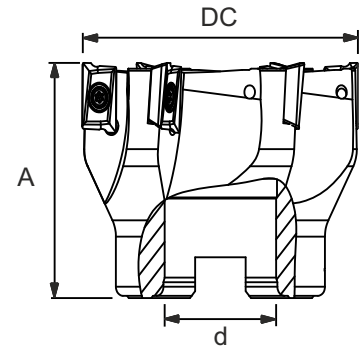

**Bestellnummer (Träger)**





Bestellnummer /Order number	Abmessungen/Dimensions (mm)				Aufnahme /Holder	IKZ
	Dc	d	A	z		
M9002040AD161604	40	16	50	4	Aufsteckdorn	●
M9002050AD221604	50	22	50	4	Aufsteckdorn	●
M9002050AD221605	50	22	50	5	Aufsteckdorn	●
M9002054AD221604	54	22	50	4	Aufsteckdorn	●
M9002054AD221605	54	22	50	5	Aufsteckdorn	●
M9002063AD221605	63	22	50	5	Aufsteckdorn	●
M9002063AD221606	63	22	50	6	Aufsteckdorn	●
M9002080AD271606	80	27	50	6	Aufsteckdorn	●
M9002080AD271607	80	27	50	7	Aufsteckdorn	●
M9002084AD271606	84	27	50	6	Aufsteckdorn	●
M9002084AD271607	84	27	50	7	Aufsteckdorn	●
M9002100AD321606	100	32	50	6	Aufsteckdorn	●
M9002100AD321608	100	32	50	8	Aufsteckdorn	●
M9002125AD401608	125	40	63	8	Aufsteckdorn	
M9002125AD401610	125	40	63	10	Aufsteckdorn	
M9002160AD401608	160	40	63	8	Aufsteckdorn	
M9002160AD401610	160	40	63	10	Aufsteckdorn	
M9002200AD601610	200	60	63	10	Aufsteckdorn	
M9002250AD601612	250	60	63	12	Aufsteckdorn	

**Ersatzteile & Zubehör / Main spare parts**

Wendeschneidplatte /Inseret	Spanschraube /Span screw	Torx
M90-1604..	T589016	T58T15

P	Stahl	M	Rostfrei	K	Guss	N	Nichteisen	S	Superlegierung	H	Hochfeste Stähle
P	Steel	M	Stainless steel	K	Cast iron	N	Non-ferrous metals	S	Heat resistant and super alloy	H	Hardened materials



	Beschichtung / Coating	CVD						U	U	PVD										
		ISO			P	M	K		N	N	P			M	S	K				
		Sorte / Grade			P1010	P1020	P1030	M2040	K3010	K3020	K3030	N4010	N4110	P1110	P1120	P1130	P1140	M2130	M2130	K3120
M=Mittlere Bearbeitung		M90160408M2											●							
		M90160408M2												●						
		M90160408M2													●					
		M90160408M2								●								●	●	
		M90160408M2									●									
LM=Schlichten / Mittlere Bearbeitung		M90160408LM2											●							
		M90160408LM2												●						
		M90160408LM2													●					
		M90160408LM2																●	●	
		M90160408LM2							●											
		M90160408LM2								●										
		M90160408LM2									●									
H=Schruppen		M90160408H2											●							
		M90160408H2												●						
		M90160408H2													●					
		M90160408H2														●				
		M90160408H2															●	●		
		M90160408H2															●			
		M90160408H3															●			
AL2=Schlichten/Mittlere Bearbeitung		M90160402AL2									●									
		M90160402AL3									●									
		M90160402AL3										●								
		M90160408AL2									●									
		M90160408AL3									●									
		M90160408AL3										●								
		M90160412AL3									●									
		M90160412AL3										●								
		M90160416AL3									●									
		M90160416AL3										●								

P	Stahl	M	Rostfrei	K	Guss	N	Nichteisen	S	Superlegierung	H	Hochfeste Stähle
P	Steel	M	Stainless steel	K	Cast iron	N	Non-ferrous metals	S	Heat resistant and super alloy	H	Hardened materials

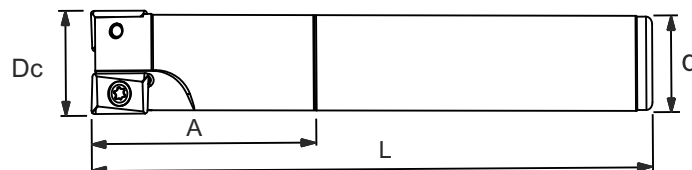

### Bestellnummer (Träger)

Bestellnummer /Order number	Abmessungen/Dimensions (mm)				Aufnahme /Holder	IKZ
	Dc	d	L	z		
M900416WE160902	16	16	125	2	Weldon	●
M900420WE200903	20	20	125	3	Weldon	●
M900425WE250904	25	25	125	4	Weldon	●
M900432WE320905	32	32	160	5	Weldon	●
M900425WE251202	25	25	125	2	Weldon	●
M900432WE321203	32	32	160	3	Weldon	●
M900440WE401204	40	40	200	4	Weldon	●

### Ersatzteile & Zubehör / Main spare parts

Wendeschneidplatte /Inseret	Spanschraube /Span screw	Torx
		
M90-0904..	T589009	T58T08
M90-1205..	T589012	T58T15

<b>P</b> Stahl	<b>M</b> Rostfrei	<b>K</b> Guss	<b>N</b> Nichteisen	<b>S</b> Superlegierung	<b>H</b> Hochfeste Stähle
<b>P</b> Steel	<b>M</b> Stainless steel	<b>K</b> Cast iron	<b>N</b> Non-ferrous metals	<b>S</b> Heat resistant and super alloy	<b>H</b> Hardened materials

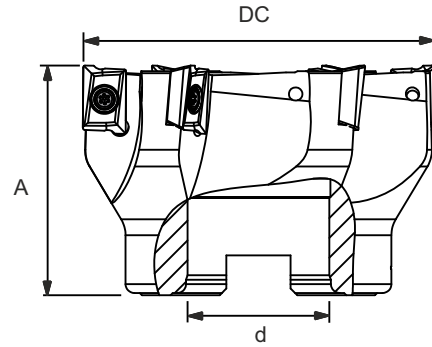

### Bestellnummer (Träger)

Bestellnummer /Order number	Abmessungen/Dimensions (mm)				Aufnahme /Holder	IKZ
	Dc	d	A	z		
M9004040AD161203	40	16	40	3	Aufsteckdorn	●
M9004050AD221204	50	22	40	4	Aufsteckdorn	●
M9004063AD271206	63	27	50	6	Aufsteckdorn	●
M9004080AD271207	80	27	50	7	Aufsteckdorn	●
M9004100AD321208	100	32	50	8	Aufsteckdorn	●
M9004125AD401210	125	40	63	10	Aufsteckdorn	
M9004160AD401212	160	40	63	12	Aufsteckdorn	
M9004040AD161703	40	16	40	3	Aufsteckdorn	●
M9004050AD221704	50	22	50	4	Aufsteckdorn	●
M9004063AD271706	63	27	50	6	Aufsteckdorn	●
M9004080AD271707	80	27	50	7	Aufsteckdorn	●
M9004100AD321708	100	32	50	8	Aufsteckdorn	●
M9004125AD401710	125	40	63	10	Aufsteckdorn	
M9004160AD401712	160	40	63	12	Aufsteckdorn	
M9004200AD601710	200	60	63	10	Aufsteckdorn	

### Ersatzteile & Zubehör / Main spare parts

Wendeschneidplatte /Inseret	Spanschraube /Span screw	Torx
M90-1205..	T589012	T58T15
M90-1706..	T589017	T58T20

<b>P</b> Stahl	<b>M</b> Rostfrei	<b>K</b> Guss	<b>N</b> Nichteisen	<b>S</b> Superlegierung	<b>H</b> Hochfeste Stähle
<b>P</b> Steel	<b>M</b> Stainless steel	<b>K</b> Cast iron	<b>N</b> Non-ferrous metals	<b>S</b> Heat resistant and super alloy	<b>H</b> Hardened materials

		Beschichtung / Coating		CVD						U	U	PVD								
		ISO		P			M	K			N	N	P			M	S	K		
		Sorte / Grade		P1010	P1020	P1030	M2040	K3010	K3020	K3030	N4010	N4110	P1110	P1120	P1130	P1140	M2130	M2130	K3120	
H=Schruppen		M90090404H4												●						
		M90090404H4																	●	
		M90090408H4													●					
		M90090408H4																	●	
		M90120504H4													●					
		M90120504H4																	●	
		M90120508H4														●				
		M90120508H4																	●	
		M90170604H4														●				
		M90170604H4																		●
		M90170608H4														●				
		M90170608H4																		●
		H=Schruppen																		
AL2=Schlichten/Mittlere Bearbeitung																				

<b>P</b>	<b>Stahl</b>	<b>M</b>	<b>Rostfrei</b>	<b>K</b>	<b>Guss</b>	<b>N</b>	<b>Nichteisen</b>	<b>S</b>	<b>Superlegierung</b>	<b>H</b>	<b>Hochfeste Stähle</b>
<b>P</b>	<b>Steel</b>	<b>M</b>	<b>Stainless steel</b>	<b>K</b>	<b>Cast iron</b>	<b>N</b>	<b>Non-ferrous metals</b>	<b>S</b>	<b>Heat resistant and super alloy</b>	<b>H</b>	<b>Hardened materials</b>

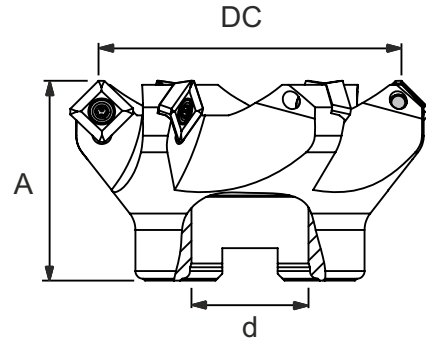

**Bestellnummer (Träger)**

Bestellnummer /Order number	Abmessungen/Dimensions (mm)				Aufnahme /Holder	IKZ
	Dc	d	A	z		
M4504040AD161204	40	16	50	4	Aufsteckdorn	●
M4504050AD221204	50	22	50	4	Aufsteckdorn	●
M4504050AD221205	50	22	50	5	Aufsteckdorn	●
M4504063AD221205	63	22	50	5	Aufsteckdorn	●
M4504063AD221206	63	22	50	6	Aufsteckdorn	●
M4504080AD271205	80	27	50	5	Aufsteckdorn	●
M4504080AD271206	80	27	50	6	Aufsteckdorn	●
M4504080AD271207	80	27	50	7	Aufsteckdorn	●
M4504080AD271208	80	27	50	8	Aufsteckdorn	●
M4504100AD321206	100	32	50	6	Aufsteckdorn	●
M4504100AD321207	100	32	50	7	Aufsteckdorn	●
M4504125AD401206	125	40	63	6	Aufsteckdorn	
M4504125AD401208	125	40	63	8	Aufsteckdorn	
M4504160AD401208	160	40	63	8	Aufsteckdorn	
M4504200AD601210	200	60	63	10	Aufsteckdorn	
M4504250AD601212	250	60	63	12	Aufsteckdorn	

**Ersatzteile & Zubehör / Main spare parts**

Wendeschneidplatte /Insert	Spanschraube /Span screw	Torx
M45-1204..	T584516	T58T20

P	Stahl	M	Rostfrei	K	Guss	N	Nichteisen	S	Superlegierung	H	Hochfeste Stähle
P	Steel	M	Stainless steel	K	Cast iron	N	Non-ferrous metals	S	Heat resistant and super alloy	H	Hardened materials

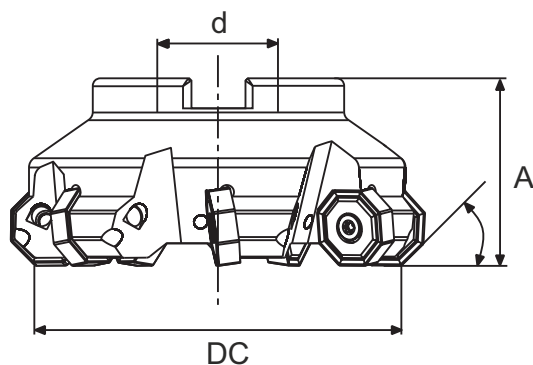





### Bestellnummer (Träger)

Bestellnummer /Order number	Abmessungen/Dimensions (mm)				Aufnahme /Holder	IKZ
	Dc	d	A	z		
M450816040AD22061204	40	22	40	4	Aufsteckdorn	●
M450816050AD22061204	50	22	50	4	Aufsteckdorn	●
M450816063AD27061206	63	27	50	6	Aufsteckdorn	●
M450816080AD27061207	80	27	50	7	Aufsteckdorn	●
M450816100AD32061208	100	32	50	8	Aufsteckdorn	●
M450816125AD40061210	125	40	63	10	Aufsteckdorn	
M450816160AD40061212	160	40	63	12	Aufsteckdorn	
M450816200AD60061214	200	60	63	14	Aufsteckdorn	
M450816250AD60061216	250	60	63	16	Aufsteckdorn	
M450816315AD60061220	315	60	63	20	Aufsteckdorn	

### Ersatzteile & Zubehör / Main spare parts

Wendeschneidplatte /Inseret	Spanschraube /Span screw	Torx
ONMU-0605..	T58-ON06	T58T15
SNMU-1205..	T58-SN12	T58T15

<b>P</b> Stahl	<b>M</b> Rostfrei	<b>K</b> Guss	<b>N</b> Nichteisen	<b>S</b> Superlegierung	<b>H</b> Hochfeste Stähle
<b>P</b> Steel	<b>M</b> Stainless steel	<b>K</b> Cast iron	<b>N</b> Non-ferrous metals	<b>S</b> Heat resistant and super alloy	<b>H</b> Hardened materials

	Beschichtung / Coating	CVD							U	U	PVD								
		ISO		P			M	K			N	N	P			M	S	K	
		Sorte / Grade		P1010	P1020	P1030	M2040	K3010	K3020	K3030	N4010	N4110	P1110	P1120	P1130	P1140	M2130	M2130	K3120
M=Mittlere Bearbeitung		M451204M2			●														
		M451204M2										●							
		M451204M2											●						
		M451204M2												●					
		M451204M2							●										
		ONMU060506H4													●				
		SNMU120515H4													●				
		SNMU120515H4																	●
MH=Mittlere Bearbeitung / Schruppen		M451204MH2										●							
		M451204MH2											●						
		M451204MH2												●					
		M451204MH2														●	●		
		M451204MH2							●										
		M451204MH2																	
H=Schruppen		M451204H2																	
		M451204H2														●	●		
		M451204H2			●														
		M451204H2											●						
		M451204H2												●					
		M451204H2													●				
		M451204H2																	
AL2=Schlichten/Mittlere Bearbeitung		M451204AL2									●								
		M451204AL3									●								
		M451204AL3											●						

P	Stahl	M	Rostfrei	K	Guss	N	Nichteisen	S	Superlegierung	H	Hochfeste Stähle
P	Steel	M	Stainless steel	K	Cast iron	N	Non-ferrous metals	S	Heat resistant and super alloy	H	Hardened materials



10°

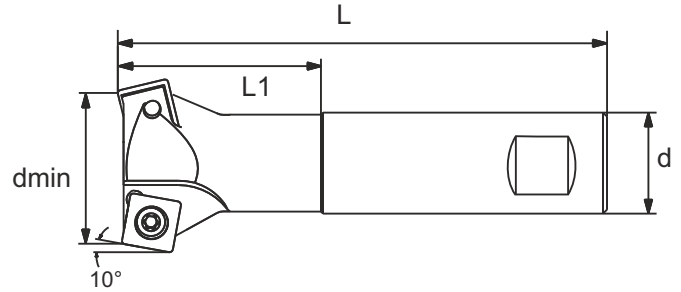

Bestellnummer (Träger)

Bestellnummer /Order number	Abmessungen/Dimensions (mm)					Aufnahme /Holder	IKZ
	dmin	d	L	L1	z		
M1004020WE200902	20	20	110	40	2	Weldon	●
M1004025WE250902	25	25	150	40	2	Weldon	●
M1004032WE320903	32	32	180	40	3	Weldon	●
M1004020WE201202	20	20	110	40	2	Weldon	●
M1004025WE251202	25	25	150	40	2	Weldon	●
M1004032WE321203	32	32	180	40	3	Weldon	●

Ersatzteile & Zubehör / Main spare parts

Wendeschneidplatte /Inseret	Spanschraube /Span screw	Torx
		
SPMT0903..	T58SPMT09	T58T10
SPMT1204..	T58SPMT12	T58T15

P	Stahl	M	Rostfrei	K	Guss	N	Nichteisen	S	Superlegierung	H	Hochfeste Stähle
P	Steel	M	Stainless steel	K	Cast iron	N	Non-ferrous metals	S	Heat resistant and super alloy	H	Hardened materials



15°

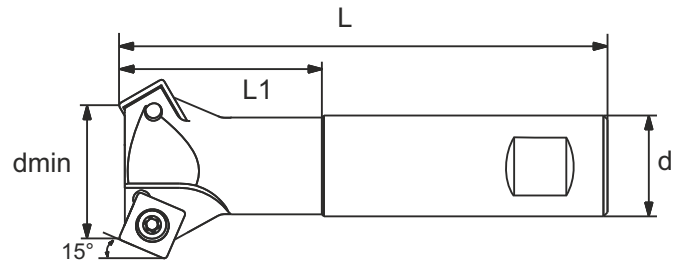

**Bestellnummer (Träger)**

Bestellnummer /Order number	Abmessungen/Dimensions (mm)					Aufnahme /Holder	IKZ
	dmin	d	L	L1	z		
M1504020WE200902	20	20	110	40	2	Weldon	●
M1504025WE250902	25	25	150	40	2	Weldon	●
M1504032WE320902	32	32	180	40	3	Weldon	●
M1504020WE201202	20	20	110	40	2	Weldon	●
M1504025WE251202	25	25	150	40	2	Weldon	●
M1504032WE321203	32	32	180	40	3	Weldon	●

**Ersatzteile & Zubehör / Main spare parts**

Wendeschneidplatte /Insert	Spanschraube /Span screw	Torx
		
SPMT0903..	T58SPMT09	T58T10
SPMT1204..	T58SPMT12	T58T15

<b>P</b> Stahl	<b>M</b> Rostfrei	<b>K</b> Guss	<b>N</b> Nichteisen	<b>S</b> Superlegierung	<b>H</b> Hochfeste Stähle
<b>P</b> Steel	<b>M</b> Stainless steel	<b>K</b> Cast iron	<b>N</b> Non-ferrous metals	<b>S</b> Heat resistant and super alloy	<b>H</b> Hardened materials



30°

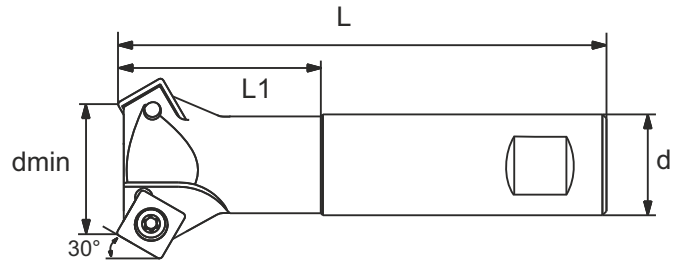

**Bestellnummer (Träger)**

Bestellnummer /Order number	Abmessungen/Dimensions (mm)					Aufnahme /Holder	IKZ
	dmin	d	L	L1	z		
M3004020WE200902	20	20	110	40	2	Weldon	●
M3004025WE250902	25	25	150	40	2	Weldon	●
M3004032WE320903	32	32	180	40	3	Weldon	●
M3004020WE201202	20	20	110	40	2	Weldon	●
M3004025WE251202	25	25	150	40	2	Weldon	●
M3004032WE321203	32	32	180	40	3	Weldon	●

**Ersatzteile & Zubehör / Main spare parts**

Wendeschneidplatte /Inseret	Spanschraube /Span screw	Torx
SPMT0903..	T58SPMT09	T58T10
SPMT1204..	T58SPMT12	T58T15

<b>P</b> Stahl	<b>M</b> Rostfrei	<b>K</b> Guss	<b>N</b> Nichteisen	<b>S</b> Superlegierung	<b>H</b> Hochfeste Stähle
<b>P</b> Steel	<b>M</b> Stainless steel	<b>K</b> Cast iron	<b>N</b> Non-ferrous metals	<b>S</b> Heat resistant and super alloy	<b>H</b> Hardened materials

60°

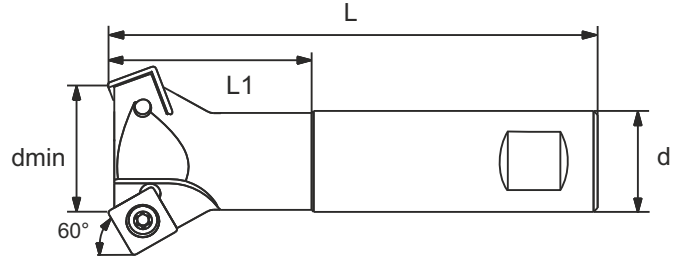

**Bestellnummer (Träger)**

Bestellnummer /Order number	Abmessungen/Dimensions (mm)					Aufnahme /Holder	IKZ
	dmin	d	L	L1	z		
M6004020WE200902	20	20	110	40	2	Weldon	●
M6004025WE250902	25	25	150	40	2	Weldon	●
M6004032WE320903	32	32	180	40	3	Weldon	●
M6004020WE201202	20	20	110	40	2	Weldon	●
M6004025WE251202	25	25	150	40	2	Weldon	●
M6004032WE321203	32	32	180	40	3	Weldon	●

**Ersatzteile & Zubehör / Main spare parts**

Wendeschneidplatte /Insert	Spanschraube /Span screw	Torx
		
SPMT0903..	T58SPMT09	T58T10
SPMT1204..	T58SPMT12	T58T15

P	Stahl	M	Rostfrei	K	Guss	N	Nichteisen	S	Superlegierung	H	Hochfeste Stähle
P	Steel	M	Stainless steel	K	Cast iron	N	Non-ferrous metals	S	Heat resistant and super alloy	H	Hardened materials



75°

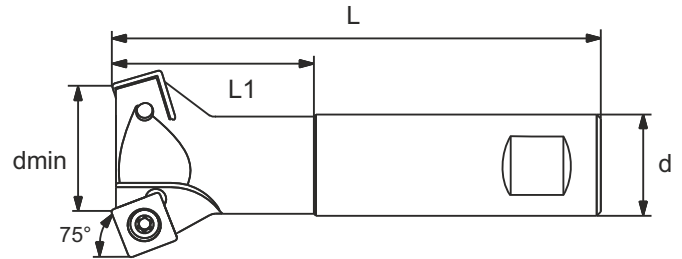

**Bestellnummer (Träger)**

Bestellnummer /Order number	Abmessungen/Dimensions (mm)					Aufnahme /Holder	IKZ
	dmin	d	L	L1	z		
M7504020WE200902	20	20	110	40	2	Weldon	●
M7504020WE250902	25	25	150	40	2	Weldon	●
M7504032WE320903	32	32	180	40	3	Weldon	●
M7504020WE201202	20	20	110	40	2	Weldon	●
M7504025WE251202	25	25	150	40	2	Weldon	●
M7504032WE321203	32	32	180	40	3	Weldon	●

**Ersatzteile & Zubehör / Main spare parts**

Wendeschneidplatte /Inseret	Spanschraube /Span screw	Torx
		
SPMT0903..	T58SPMT09	T58T10
SPMT1204..	T58SPMT12	T58T15

P	Stahl	M	Rostfrei	K	Guss	N	Nichteisen	S	Superlegierung	H	Hochfeste Stähle
P	Steel	M	Stainless steel	K	Cast iron	N	Non-ferrous metals	S	Heat resistant and super alloy	H	Hardened materials

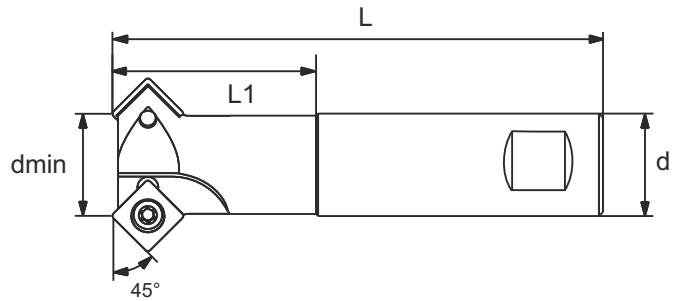
**45°****Bestellnummer (Träger)**

Bestellnummer /Order number	Abmessungen/Dimensions (mm)					Aufnahme /Holder	IKZ
	dmin	d	L	L1	z		
M4504020WE200902	20	20	110	40	2	Weldon	●
M4504025WE250902	25	25	150	40	2	Weldon	●
M4504032WE320903	32	32	180	40	3	Weldon	●
M4504020WE201202	20	20	110	40	2	Weldon	●
M4504025WE251202	25	25	150	40	2	Weldon	●
M4504032WE321203	32	32	180	40	3	Weldon	●

**Ersatzteile & Zubehör / Main spare parts**

Wendeschnidplatte /Insert	Spanschraube /Span screw	Torx
SPMT0903..	T58SPMT09	T58T10
SPMT1204..	T58SPMT12	T58T15

<b>P</b> Stahl	<b>M</b> Rostfrei	<b>K</b> Guss	<b>N</b> Nichteisen	<b>S</b> Superlegierung	<b>H</b> Hochfeste Stähle
<b>P</b> Steel	<b>M</b> Stainless steel	<b>K</b> Cast iron	<b>N</b> Non-ferrous metals	<b>S</b> Heat resistant and super alloy	<b>H</b> Hardened materials

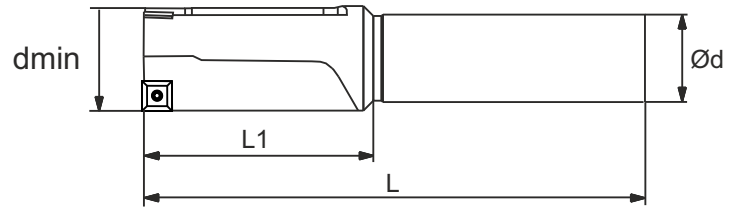

**Bestellnummer (Träger)**

Bestellnummer /Order number	Abmessungen/Dimensions (mm)					Aufnahme /Holder	IKZ
	Dc	d	L	L1	z		
M18004011WE101030601	11	10	103	23	1	Weldon	●
M18004014WE121080601	14	12	108	28	1	Weldon	●
M18004016WE151150602	16	15	115	49	2	Weldon	●
M180040175WE161150602	17,5	16	115	35	2	Weldon	●
M18004018WE161170602	18	16	117	35	2	Weldon	●
M18004020WE161200603	20	16	120	40	3	Weldon	●
M18004022WE201240603	22	20	124	44	3	Weldon	●
M18004023WE201260603	23	20	126	46	3	Weldon	●
M18004024WE201280603	24	20	128	48	3	Weldon	●
M18004025WE201300603	25	20	130	50	3	Weldon	●
M18004026WE251320903	26	25	132	52	3	Weldon	●
M18004027WE251340903	27	25	134	54	3	Weldon	●
M18004028WE251360903	28	25	136	56	3	Weldon	●
M18004029WE251380903	29	25	138	58	3	Weldon	●
M18004030WE251400903	30	25	140	60	3	Weldon	●
M18004032WE251440903	32	25	144	64	3	Weldon	●
M18004035WE321500903	35	32	150	70	3	Weldon	●
M18004039WE321580904	39	32	158	78	4	Weldon	●
M18004043WE321660904	43	32	166	86	4	Weldon	●
M18004048WE321760904	48	32	176	96	4	Weldon	●

**Ersatzteile & Zubehör / Main spare parts**

Wendeschnidplatte /Inseret	Spanschraube /Span screw	Torx
SPMT0903..	T58SPMT09	T58T10
SPMT1204..	T58SPMT12	T58T15

<b>P</b> Stahl	<b>M</b> Rostfrei	<b>K</b> Guss	<b>N</b> Nichteisen	<b>S</b> Superlegierung	<b>H</b> Hochfeste Stähle
<b>P</b> Steel	<b>M</b> Stainless steel	<b>K</b> Cast iron	<b>N</b> Non-ferrous metals	<b>S</b> Heat resistant and super alloy	<b>H</b> Hardened materials

		Beschichtung / Coating	CVD						U	U	PVD								
		ISO	P			M	K			N	N	P				M	S	K	
		Sorte / Grade	P1010	P1020	P1030	M2040	K3010	K3020	K3030	N4010	N4110	P1110	P1120	P1130	P1140	M2130	M2130	K3120	
M=Mittlere Bearbeitung		SPMT090308M2																	
		SPMT120408M2				●													
MH=Mittlere Bearbeitung / Schruppen																			
H=Schruppen																			
AL2=Schlichten/Mittlere Bearbeitung																			

P	Stahl	M	Rostfrei	K	Guss	N	Nichteisen	S	Superlegierung	H	Hochfeste Stähle
P	Steel	M	Stainless steel	K	Cast iron	N	Non-ferrous metals	S	Heat resistant and super alloy	H	Hardened materials